

Interactive comment on “Estimation of the total magnetization direction of approximately spherical bodies” by V. C. Oliveira Jr. et al.

V. C. Oliveira Jr. et al.

vandscoelho@gmail.com

Received and published: 12 December 2014

We would like to thank Referee P. Lelièvre for his review. Below we present our comments and responses to his recommendations. We have performed several new tests on synthetic data that we hope will clarify several points raised by the Referee. The results, figures, and source code for these tests are available online through the code hosting website Github at github.com/birocoles/Total-magnetization-of-spherical-bodies. Links to each specific synthetic test are provided in the relevant comments below.

General comments

Referee's comment: *"The forward problem described is essentially identical to a mesh-C693*

based discretization but with the space-filling mesh cells (prisms, tetrahedra, etc) replaced with spherical (dipole) sources. Hence, the methods presented are essentially identical to those used by Lelièvre and Oldenburg (2009) and Ellis et al. (2012)."

We fully disagree with your comment that the forward problem in our method is **essentially identical** to the one adopted by Lelièvre and Oldenburg (2009).

The interpretation model adopted by Lelièvre and Oldenburg (2009) consists of an $m_x \times m_y \times m_z$ grid of 3D juxtaposed prisms in the horizontal and vertical directions (Figure 1). Hence, in the Lelièvre and Oldenburg (2009) the associated forward model (their equation 10) requires computing the N by $3M$ full sensitivity matrix being N the number of data and M the number of prisms of the interpretation model. A large data set combined with the discretization of the Earth's subsurface into a fine grid of prisms results in a large-scale 3D forward model. Notice that in our method we **do not** discretize the earth's subsurface into an $m_x \times m_y \times m_z$ grid of 3D juxtaposed dipoles in the horizontal and vertical directions. Hence, our interpretation model does not consist of a 3D, equally spaced array of dipoles. Rather, the forward problem adopted by our method consists of a set of L dipoles (Figure 2). Hence, in our method the associated forward model (our equation 16) requires computing the N by $3L$ sensitivity matrix where $L \lllll M$. Thus, our method deals with a small-scale forward model being completely different from the one adopted by Lelièvre and Oldenburg (2009).

Referee's comment: *"The difference is that where Lelièvre, Ellis et al. develop methods to solve an underdetermined inverse problem (many more mesh cells than data observations), the authors of this manuscript only consider the solution of a simpler overdetermined problem (far fewer source parameters than data observations)."*

We agree that Lelièvre and Oldenburg's (2009) method solves an underdetermined inverse problem while our method solves an overdetermined problem. However,

this characteristic is not the unique difference between these approaches. Figure 3 presents a list of the characteristics found in Lelièvre and Oldenburg' (2009) method in comparison with those found in our method in this manuscript. By analyzing the Figure 3, we can easily conclude that these methods are substantially different. We highlighted (in green) the only two characteristics of these methods that are equal.

Computational efficiency

Lelièvre and Oldenburg's (2009) methods requires a costly computational effort (a large amount of memory storage and processing time). This disadvantage requires computational strategies to handle with a large-scale 3D inversion which were not mentioned by Lelièvre and Oldenburg (2009). The price paid for estimating the 3D magnetization vector distribution through the solution of a constrained nonlinear optimization problem is the disadvantage of dealing with intractable large-scale 3-D inversion. Hence, the computational inefficiency is one of the disadvantages of Lelièvre and Oldenburg's (2009) methods.

Our method estimates a single magnetization vector per magnetic anomaly through the solution of a linear inverse problem or a nonlinear inverse problem. Our method requires neither high-speed computers nor efficient computational strategies. The practical implementation of our method is very simple and its application is extremely fast. Hence, the major advantage of our method is its computational efficiency that allows a rapid estimation of the magnetization direction (inclination and declination) per magnetic anomaly. One might think that our method requires a signal separation to isolate the effect of a single well-defined peak per anomaly. This is not true. Our method requires only that each magnetic anomaly be identified by the interpreter. Thus, we can estimate the magnetization vectors of multiple sources by inverting a large magnetic data set; however each one estimate will be associated to a single magnetic anomaly previously identified by the interpreter.

Ill-posed vs. well-posed inverse problems

C695

We recall that the nonuniqueness of the geophysical problem is caused by the insufficient information in the geophysical data. Particularly, the main ambiguity in geophysical interpretation is the one involving the physical property and the volume of the source. There is NO WAY to estimate both at the same time just from the data. As a result, if details about the source shape are required by the interpreter, the introduction of a large amount of strong constraints is mandatory. This is the case of the Lelièvre and Oldenburg's (2009) method. These authors are using strong constraints because they are trying to retrieve both the shapes and the magnetization directions of the sources at each small volume (prism) of the $m_x \times m_y \times m_z$ grid of 3D juxtaposed prisms in the horizontal and vertical directions (Figure 1).

Lelièvre and Oldenburg (2009) deal with a high degree of nonuniqueness (an ill-posed inverse problem). To transform this ill-posed inverse problem into a well-posed one, Lelièvre and Oldenburg (2009) use supplementary information (constraints). This means that Lelièvre and Oldenburg's (2009) methods requires **a plethora of inversion control variables**. Explicitly, in their equations 19, 22 and 26, there are two inversion control variables (β and γ) and six vectors of reference models (\mathbf{p}_{ref} , \mathbf{t}_{ref} , \mathbf{s}_{ref} , \mathbf{a}_{ref} , θ_{ref} , and ϕ_{ref}). Besides, their equations 22 and 26 require much more inversion control variables, which are associated with the regularization functions \mathbf{W}_p , \mathbf{W}_s , \mathbf{W}_t , \mathbf{W}_a , \mathbf{W}_θ , and \mathbf{W}_ϕ . These regularization functions are equivalent to the regularization function \mathbf{W}_m and the depth weighting function in Li and Oldenburg, 1996. The inversion control variables associated with the regularization functions and the depth weighting function were omitted in the Lelièvre and Oldenburg (2009). **The definition of an overabundance of inversion control variables is not a trivial task**. Hence, this is one of the disadvantages of this method.

Our method in this manuscript reduces the demand of information of the magnetic sources. By assuming a spherical source, our method estimates a single magnetization vector per magnetic anomaly. As a result, the ambiguity involving the physical property (the magnetization vector, i.e., the magnetization intensity, inclination and dec-

C696

lination) and volume is not present because we assume a spherical source. Hence, we propose in this manuscript a well-posed inverse problem of estimating a single magnetization direction per anomaly by using the assumption that the magnetic source is a sphere. Hence, our method does not require constraints and the inversion control variables.

Conceptually, Lelièvre and Oldenburg's (2009) method seems a flexible method because it estimates a 3D magnetization vector distribution of the entire subsurface region containing the anomalous source. However, it does not mean that it is feasible. A concrete example of its unfeasibility is the real application presented in Lelièvre and Oldenburg's (2009) method. This inversion does not provide the magnetization direction of the sources.

Referee's comment: *"The same overdetermined problem can be solved by the methods of Lelièvre, Ellis et al.."*

We fully disagree with your comment. In Lelièvre and Oldenburg (2009), the 3D magnetization vector distribution is estimated by solving a large-scale 3D constrained non-linear inversion (their Equations 21-22 and 25-26) that involves the number of data N and the number of prisms M of the interpretation model multiplied by three (i.e. $3M$ their equation 7). Indeed, if $N < 3M$, the Lelièvre and Oldenburg's (2009) method can be formulated as an overdetermined problem. However, we stress that usually we deal with a massive magnetic data set. Hence, N can be smaller than $3M$, however N will not be much smaller than $3M$.

Referee's comment: *"As such, there is little new material here and I don't see what value this paper adds to the scientific community"*

We fully disagree with you. We presented a **new** and **very fast** total-field anomaly
C697

inversion to estimate the magnetization direction of multiple sources. The main advantages of our method are: 1) the simplicity in implementation, 2) the low computational effort and 3) the extremely rapid estimation of the magnetization direction (inclination and declination) per magnetic anomaly.

We formulate a well-posed magnetic inversion by assuming spherical shapes for the sources. One might think that it could be a severe restriction in applying our method. However, we take advantage of the upward continuation of the total-field anomaly to make possible the application of our method to interpret non-spherical sources. We illustrate the robustness of our method against non-spherical sources by inverting non-dipolar total-field anomalies. We show that the upward continuation is useful for overcoming the difficulties in the interpretation of strongly non-dipolar total-field anomalies (see subsection 3.3 Robustness against non-spherical sources). Our method requires the x -, y - and z -coordinates of the centre of the magnetic source. We show that the estimate of the magnetic direction (declination and inclination) is less sensitive to a wrong choice for the depth of the centre of the source than the horizontal coordinates of the centre of the source. Hence, a wrong choice of the depth of the centre of the source can be assumed by our method. However, we cannot assume a wrong choice of the horizontal coordinates of the centre of the source; otherwise our method estimates an incorrect magnetization direction of the source.

Referee's comment: *"The authors' suggestion of upward continuation to aid the applicability of their methods is not particularly insightful: the response of nondipole sources look more and more like dipole responses as the data measurement level is moved further from the sources (this is a well known phenomenon)."*

We neither suggest nor claim that the use of upward continuation in our manuscript is insightful. We explicitly apply the upward continuation because this is well-known phenomenon, i.e., the greater the distance between the sources

and the data, the greater the attenuation of the non-dipolar features. This emphasized sentence in italic is **explicitly stated in our manuscript (see page 20)**. Our synthetic and real tests show how the upward continuation can be used to make possible the application of our method to interpret non-spherical sources.

Referee's comment: "There is a tremendous amount of prior knowledge required about the sources to use these methods, despite the authors claiming the opposite in their conclusion: one must assume the sources are somewhat spherical, and one must have a reliable estimate of the number of sources and their locations (lateral and depth)."

We fully disagree with you. You are confusing **ASSUMED PREMISE** and **PRIOR INFORMATION**. Let us clarify these topics.

THE ASSUMED PREMISE IN OUR METHOD - We assumed a magnetized spherical source giving rise to dipolar anomalies. Notice that **it does not mean that the source must be a sphere**. We show the feasibility of applying the upward continuation to interpret non-spherical sources by using synthetic tests. We **simulated 11 prismatic sources** with different side lengths L_x , L_y and L_z (Figure 4 in our manuscript displays three prisms) giving rise to non-dipolar total field anomalies. Figure 5 (in our manuscript) displays the total field anomalies produced by three prismatic sources at the plane $z = 0$ unit (Fig 5a-c) and the upward-continued anomalies at $z = -0.3$ unit (Fig 5 d-f) and at $z = -0.6$ unit (Fig 5 g-i). By inverting the upward-continued anomalies (e.g., Fig. 5d-i), the least-squares estimates are approximately similar to the robust estimates (Fig. 6c-f). Hence, Figure 6c-f shows that the estimated declination and inclination by inverting the upward-continued anomalies (e.g., Fig. 5d-i) **are in close agreement with true magnetization direction of the 11 simulated non-spherical sources**. Besides, in this review we simulated other examples of non-spherical sources. The results, figures, and numerical codes used to produce these results can be found online in the IPython notebooks (an interac-

C699

tive writing and programming environment) [synthetic_tests_sphere_prism.ipynb](#), [complex_test.ipynb](#), [synthetic_tests-L2.ipynb](#), and [synthetic_tests-L1.ipynb](#). Among these additional tests, we not only illustrate the application of our method to interpret simple sources, but also show the performance of our method in estimating the magnetization direction of synthetic models similar to that ones presented by Lelièvre and Oldenburg (2009) and Ellis, Wet and Macleod (2012).

THE PRIOR INFORMATION REQUIRED BY OUR METHOD – Our method requires the x -, y - and z -coordinates of the centre of the magnetic source. We investigate the sensitivity of our method to uncertainties in the a priori information (i.e., location of the centre of the magnetic source). Figure 7 in our manuscript shows that the wrong choice of the x and y coordinates of the centre of the source leads to poor estimates of the magnetization direction (declinations and inclinations in Fig. 7a–d) when compared with the true magnetization vector (continuous black lines in Fig. 7). On the other hand, the estimated declinations and inclinations are less sensitive to the wrong choice of the z coordinate of the centre of the source (Fig. 7e and f). Figure 7 **shows 126 (one hundred and twenty six)** inversions by presuming different positions of x -, y - and z -coordinates of the centre of the source. These results show that our method is more sensitive to errors in the assumed horizontal coordinates of the centre of the source (x - and y -coordinates) than in the assumed the depth (z -coordinate) of centre of the source. Hence, the wrong choice of the depth of the centre of the source does not prevent the correct estimation of the magnetization direction (declination and inclination). Rather, the wrong choice of the horizontal coordinates of the centre of the source prevents the correct estimation of the magnetic direction.

In our manuscript, we stated that we use the Euler deconvolution to estimate x -, y - and z -coordinates of the centre of the magnetic source. We explicitly stated "*One might think that the high sensitivity of our method to uncertainties in the horizontal coordinates of the centres of the sources is a drawback. This is not true because these coordinates are generally well estimated by the Euler deconvolution*". The horizon-

C700

tal position estimates by Euler deconvolution is unique and stable (Silva and Barbosa, 2003) even in the presence of noise and wrong structural index. Hence, **the horizontal coordinates are well estimated by the Euler deconvolution**. Of course, if the bodies yield strong-interfering anomalies the Euler deconvolution fails in estimating the x - and y -coordinates of the bodies and thus the magnetization direction will be wrongly estimated by our method. In our manuscript, **we present 126 (one hundred and twenty six) inversions** by presuming different positions of x -, y - and z -coordinates of the centre of the source (Figure 7) and **in this review we simulated other examples evaluating the sensitive to uncertainties in the a priori information about the horizontal coordinates of the centre of the non-spherical sources**. The results, figures, and numerical codes used to produce these results can be found online in the IPython notebooks (an interactive writing and programming environment) [synthetic_tests_sphere_prism.ipynb](#), [complex_test.ipynb](#), [synthetic_tests-L2.ipynb](#), and [synthetic_tests-L1.ipynb](#).

Finally, we stress that, in our method, the prior information and the assumed premises are **explicitly** stated. They are not hidden in the constraints (e.g., regularizing functions and depth weighting function). Besides, the solution sensitivity to uncertainties in defining the prior information and the assumed premises are widely tested by using synthetic tests. Hence, the advantages and restrictions of our method were analysed in our manuscript.

Referee's comment: *"As such, I don't see these methods being widely applicable."*

We fully disagree with you. We presented a **very fast** and well-posed magnetic inversion to estimate the magnetization direction of multiple sources. Our method deals with a **very small** optimization problem that leads to fast inversion times and low memory usage, making viable the inversion of large data sets **without needing supercomputers or data compression algorithms**. We are solving a well-posed inverse problem of estimating a single magnetization direction per anomaly by using the assumption

C701

that the magnetic source is a sphere. Hence, **our method does not require a large amount of constraints and their inversion control variables**.

Our method, **as all methods**, presents **advantages and restrictions**. The advantages and restrictions make a given method more suitable to be used under a given available amount of a priori geological information about the sources. **There is no universal inversion method applicable to all geological settings**. Rather, an inversion method can be applied only to a specific geological setting because of the inevitable bias imposed either by the stabilizing constraints or by the assumed premise. Moreover, the **practical applicability of a method also depends on its computational feasibility**. An intractable large-scale 3D inversion usually requires: 1) large amount of constraints, 2) large amount of inversion control variables, 3) supercomputers or clusters of computers and 4) data compression algorithms. Finally, **the practical applicability of a method also depends on its reproducibility**. The reproducibility is one of the main principles of the scientific method. All the specific variables of the synthetic and real tests must be present in the text, so that the work is reproducible. Without reproducibility, experimental trials that confirm or deny a given hypothesis cannot be confirmed by other scientists. In our manuscript, the premises, the prior information and the variables used for simulating our tests are explicitly present in the text. Besides, we have already made available the code of our program to be used by other scientists at <http://fatiando.readthedocs.org/en/v0.3/api/gravmag.magdir.html#module-fatiando.gravmag.magdir>. Our method is part of the open-source Python toolkit for geophysical modeling and inversion called **Fatiando a Terra** (<http://fatiando.org/>).

References

Silva, J. B. C. and V. C. F. Barbosa, 2003, 3D Euler deconvolution: Theoretical basis for automatically selecting good solutions. *Geophysics*, 68(6), 1962–1968, doi: 10.1190/1.1635050

C702

Lelièvre, P. G. and D. W. Oldenburg, 2009, A 3D total magnetization inversion applicable when significant, complicated remanence is present. *Geophysics*, 74(3), L21–L30, doi: 10.1190/1.3103249

Ellis, R. G., B. Wet and I. N. Macleod, 2012, Inversion of magnetic data from remanent and induced sources: 22nd International geophysical conference and exhibition, ASEG, Expanded Abstracts, 1-4.

Interactive comment on Nonlin. Processes Geophys. Discuss., 1, 1465, 2014.

C703

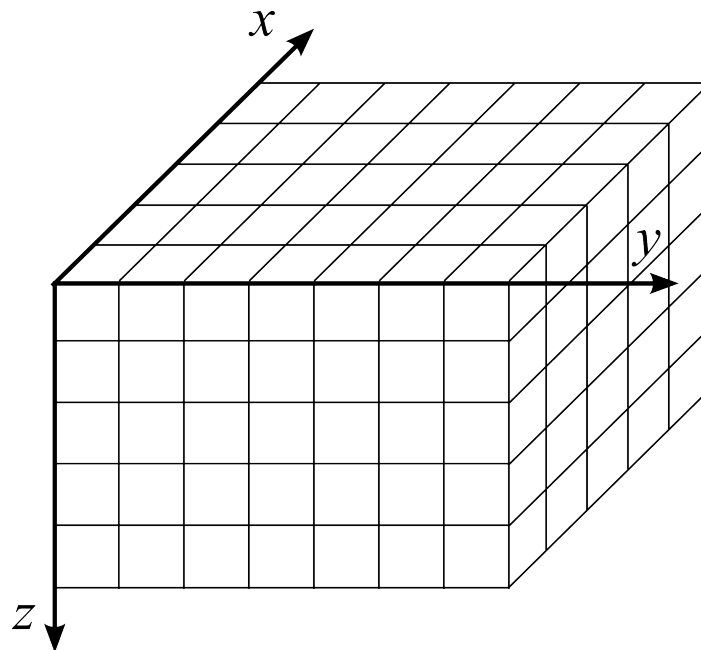

Fig. 1. Interpretation model used by Lelièvre and Oldenburg's (2009) method. This interpretation model is formed by a grid of 3D juxtaped prisms.

C704

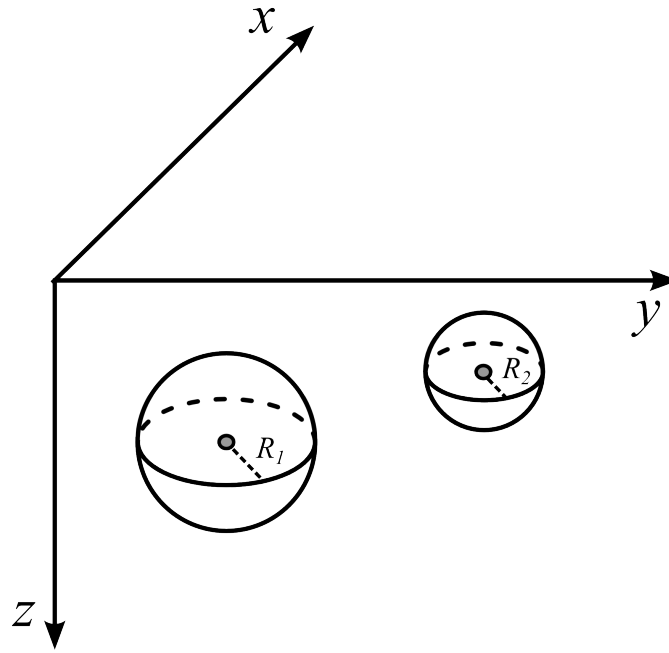

Fig. 2. Interpretation model used by our method. This interpretation model is formed by two spheres with different centres and radii.

C705

	Characteristics of Lelièvre and Oldenburg's (2009) method	Characteristics of our method
Interpretation model consists of a user-specified grid of M juxtaposed prisms in the horizontal and vertical directions	Yes	No
Interpretation model consists of a user-specified set of a few dipoles	No	Yes
A large-scale forward model	Yes	No
Inversion method for estimating the magnetization vector of geological bodies	Yes	Yes
The Cartesian and Spherical formulations for estimating the magnetization vector	Yes	Yes
An underdetermined optimization approach	Yes	No
An overdetermined optimization approach	No	Yes
High degree of nonuniqueness (ill-posed inverse problem)	Yes	No
The use of Tikhonov regularization to transform an ill-posed inverse problem into a well-posed one	Yes	No
The use of unorthodox procedure to reduce the nonuniqueness (e.g., removing padding cells)	Yes	No
A plethora of control parameters the prior information)	Yes	No
Inversion method that recovers the 3D magnetization vector distribution	Yes	No
Inversion method that presumes the shape of the geologic bodies	No	Yes
Inversion method that recovers a single magnetization direction per anomaly	No	Yes

Fig. 3. Comparison between the Lelièvre and Oldenburg's (2009) method and our method.

C706